

8 7 6 5 4 3 2 1

REVISIONS			
REV.	DESCRIPTION	DATE	APPROVED
A	RELEASED FOR PRODUCTION	10/22/2014	KRW

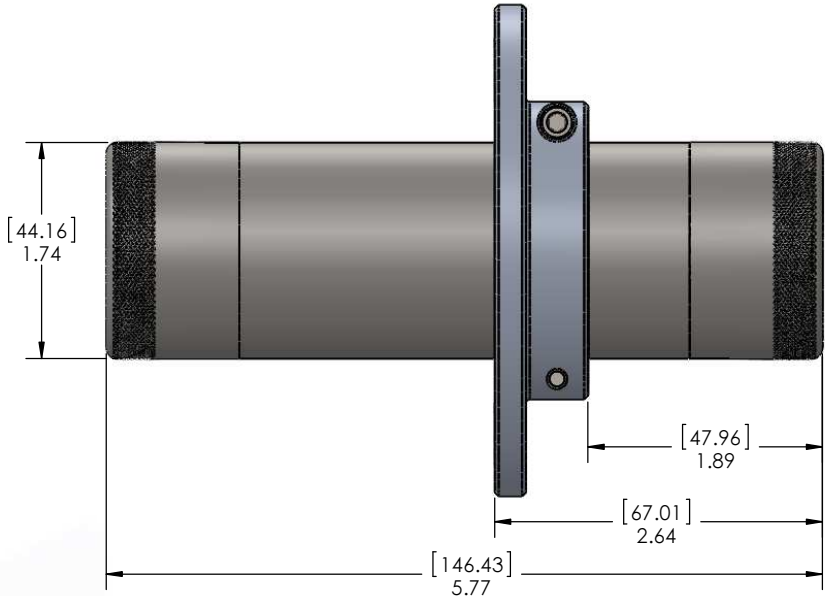
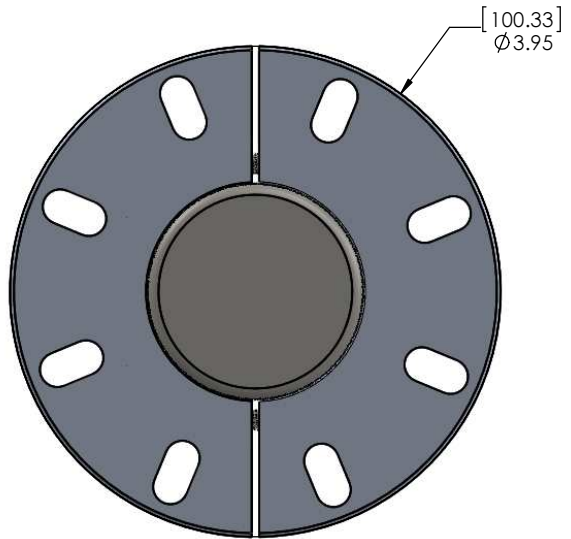

V:\X300\Mechanical Models\X300-2\C\RELEASE\ 81-05-0097-00 GENERAL ASSEMBLY X300-2C WITH FLANGE

		UNLESS OTHERWISE SPECIFIED:	NAME	DATE
		DIMENSIONS ARE IN INCHES	DRAWN	KRW
		TOLERANCES:	CHECKED	10/20/2014
		FRACTIONAL ± 1/32	ENG APPR.	
		ANGULAR: ± 2°	MFG APPR.	
		TWO PLACE DECIMAL ± .03	Q.A.	
		THREE PLACE DECIMAL ± .010	COMMENTS:	
		INTERPRET GEOMETRIC TOLERANCING PER: ASME Y14.5M - 1994		
		MATERIAL		
		FINISH		
NEXT ASSY	USED ON			
		APPLICATION	DO NOT SCALE DRAWING	ECR #:

CDI

TITLE:  
GENERAL ASSEMBLY,  
X300-2C

SIZE	DWG. NO.	REV
B	81-05-0097-00	A
SCALE: 1:2		WEIGHT: 1.9LBS
SHEET 1 OF 1		

- NOTES**
- DIMENSIONS ARE IN INCHES AND [MILLIMETERS]
  - MAXIMUM OPERATING PRESSURE: 2500PSI
  - APPROXIMATE WEIGHT: 1.9LBS

**PROPRIETARY AND CONFIDENTIAL**  
THE INFORMATION CONTAINED IN THIS DRAWING IS THE SOLE PROPERTY OF CDI. ANY REPRODUCTION IN PART OR AS A WHOLE WITHOUT THE WRITTEN PERMISSION OF CDI IS PROHIBITED.

8 7 6 5 4 3 2 1