

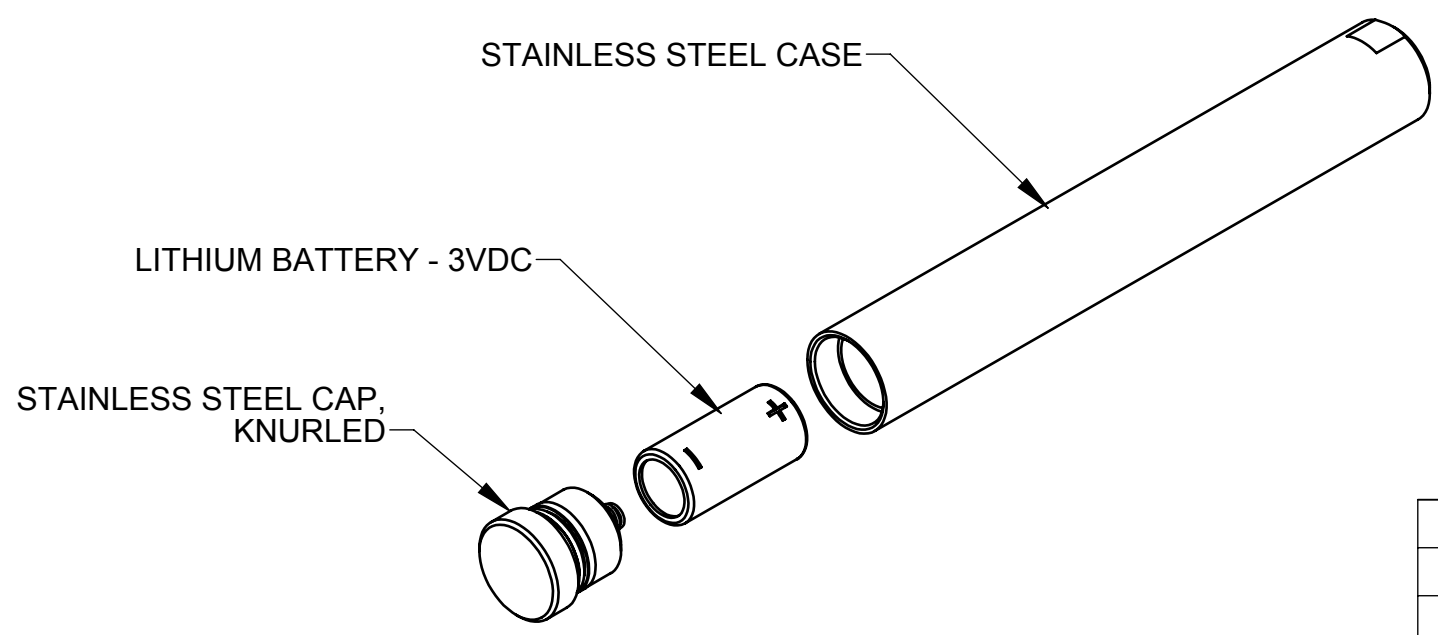

REVISIONS			
REV.	DESCRIPTION	DATE	APPROVED
A	RELEASE REVISION	5/29/2009	DS

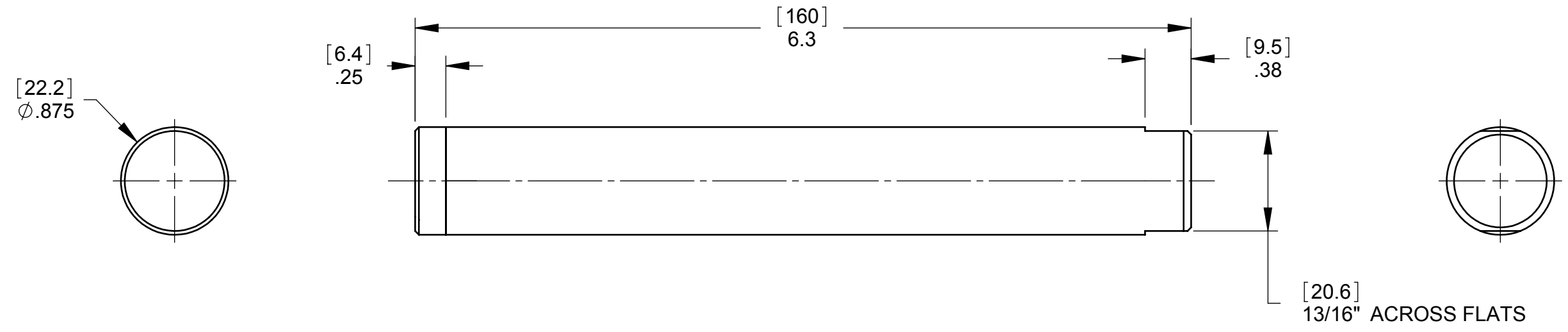

- NOTES:
1. DIMENSIONS ARE IN INCHES AND [MILLIMETERS].
 2. OPERATING PRESSURE: 2500 PSI [172.4 BAR] MAX.
 3. OPERATING TEMPERATURE: -40°F TO 140°F [-40°C TO 60°C].
 4. WEIGHT: 11oz [312g].
 5. BATTERY LIFE: 110 HOURS (STANDARD PULSE)
150 HOURS (SKIP ONE PULSE)
 6. RANGE: 30 FEET [9.2 METERS].

PROPRIETARY AND CONFIDENTIAL
 THE INFORMATION CONTAINED IN THIS DRAWING IS THE SOLE PROPERTY OF CDI. ANY REPRODUCTION IN PART OR AS A WHOLE WITHOUT THE WRITTEN PERMISSION OF CDI IS PROHIBITED.

UNLESS OTHERWISE SPECIFIED:		NAME	DATE	
DIMENSIONS ARE IN INCHES		DRAWN	DS	
TOLERANCES:		CHECKED		
FRACTIONAL ± 1/32		ENG APPR.		
ANGULAR: ± 2°		MFG APPR.		
TWO PLACE DECIMAL ± .03		Q.A.		
THREE PLACE DECIMAL ± .010		COMMENTS:		
INTERPRET GEOMETRIC TOLERANCING PER: ASME Y14.5M - 1994				
MATERIAL				
FINISH				
NEXT ASSY	USED ON			
APPLICATION		ECN #:		
DO NOT SCALE DRAWING				

TITLE: GENERAL ARRANGEMENT, CD42-T3HP		
SIZE B	DWG. NO. 81-03-0046E	REV A
SCALE:	WEIGHT: 11 oz	SHEET 1 OF 1

81-03-0046E - GENERAL ARRANGEMENT, CD42-T3HP