

REV.	DESCRIPTION	DATE	APPROVED
A	RELEASE TO PRODUCTION	3/21/2017	KRW

NOTES:

[5.33]
.210

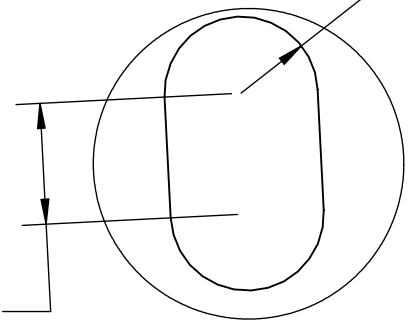

DETAIL A
SCALE 3 : 1

PROPRIETARY AND CONFIDENTIAL
THE INFORMATION CONTAINED IN THIS DRAWING IS THE SOLE PROPERTY OF CDI. ANY REPRODUCTION IN PART OR AS A WHOLE WITHOUT THE WRITTEN PERMISSION OF CDI IS PROHIBITED.



		UNLESS OTHERWISE SPECIFIED: DIMENSIONS ARE IN INCHES TOLERANCES: FRACTIONAL: ± 1/32 ANGULAR: ± 2° TWO PLACE DECIMAL: ± .03 THREE PLACE DECIMAL: ± .010	APPROVED BY GROUP DATE:	<h1>CDI</h1>
		INTERPRET GEOMETRIC TOLERANCING PER: ASME Y14.5M - 1994	DRAWING STATE	
MATERIAL			COMMENTS:	SIZE DWG. NO. REV B 81-03-0099-00 A
NEXT ASSY	USED ON	FINISH	ECR #:	SCALE: 1.5:1 WEIGHT: SHEET 1 OF 1
APPLICATION		DO NOT SCALE DRAWING		