

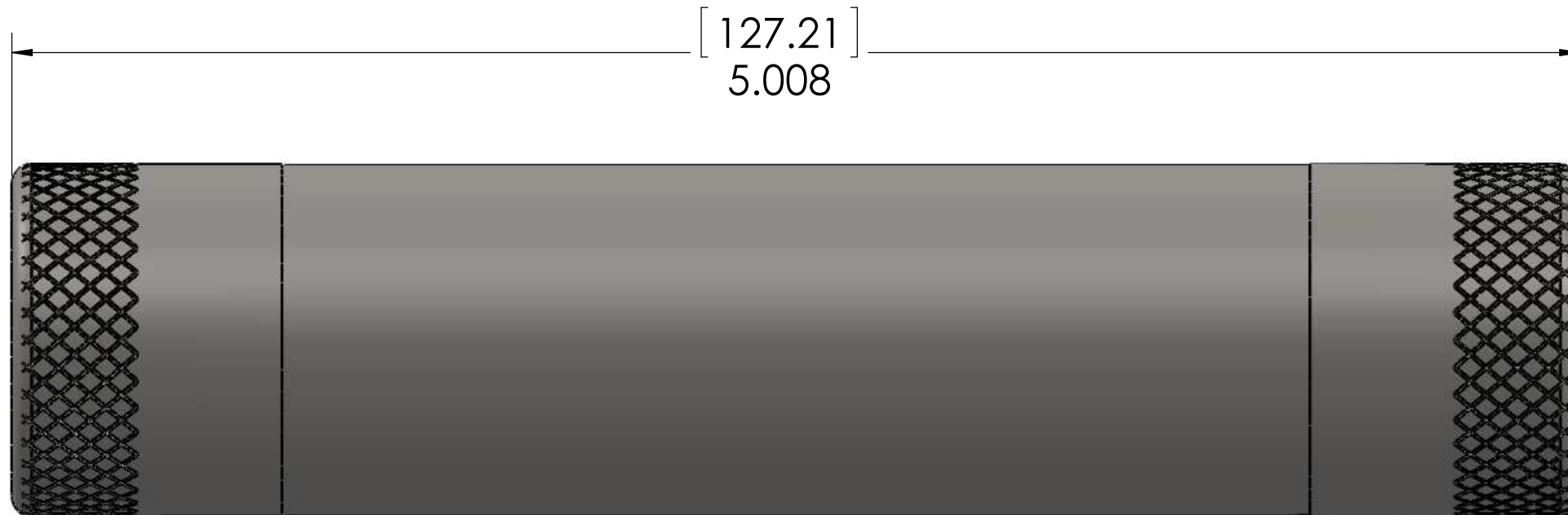

REV.	DESCRIPTION	DATE	APPROVED
1	RELEASE TO PRODUCTION	4/22/2015	KRW

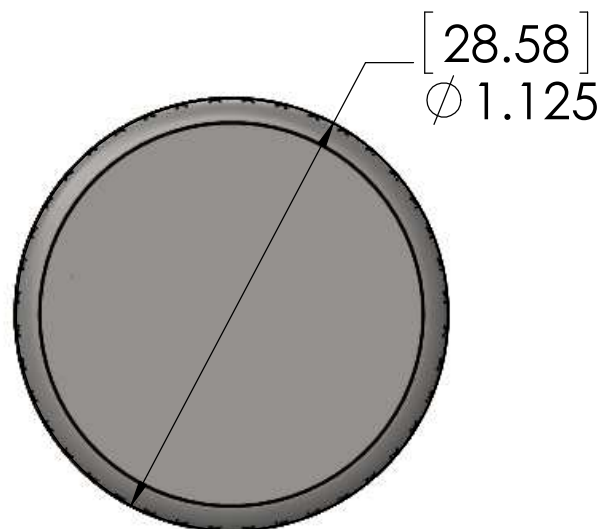

PROPRIETARY AND CONFIDENTIAL
 THE INFORMATION CONTAINED IN THIS DRAWING IS THE SOLE PROPERTY OF CDI. ANY REPRODUCTION IN PART OR AS A WHOLE WITHOUT THE WRITTEN PERMISSION OF CDI IS PROHIBITED.

		UNLESS OTHERWISE SPECIFIED: DIMENSIONS ARE IN INCHES TOLERANCES: FRACTIONAL \pm 1/32 ANGULAR: \pm 2° TWO PLACE DECIMAL \pm .03 THREE PLACE DECIMAL \pm .010		NAME	DATE	 TITLE: GENERAL ASSEMBLY, X200-2AA
			DRAWN			
			CHECKED			
			ENG APPR.			
		INTERPRET GEOMETRIC TOLERANCING PER: ASME Y14.5M - 1994				
		MATERIAL				
		FINISH				
NEXT ASSY	USED ON					SIZE B DWG. NO. 81-03-0099-00 REV 1
APPLICATION		DO NOT SCALE DRAWING	ECN #:			SCALE: 1:1 WEIGHT: SHEET 1 OF 1

V:\X200\X200-2AA\ 81-03-0098-00 GENERAL ASSEMBLY, X200-2AA NOT PRELIM