

REVISIONS			
REV.	DESCRIPTION	DATE	APPROVED
A	RELEASE REVISION	1/24/2011	DS

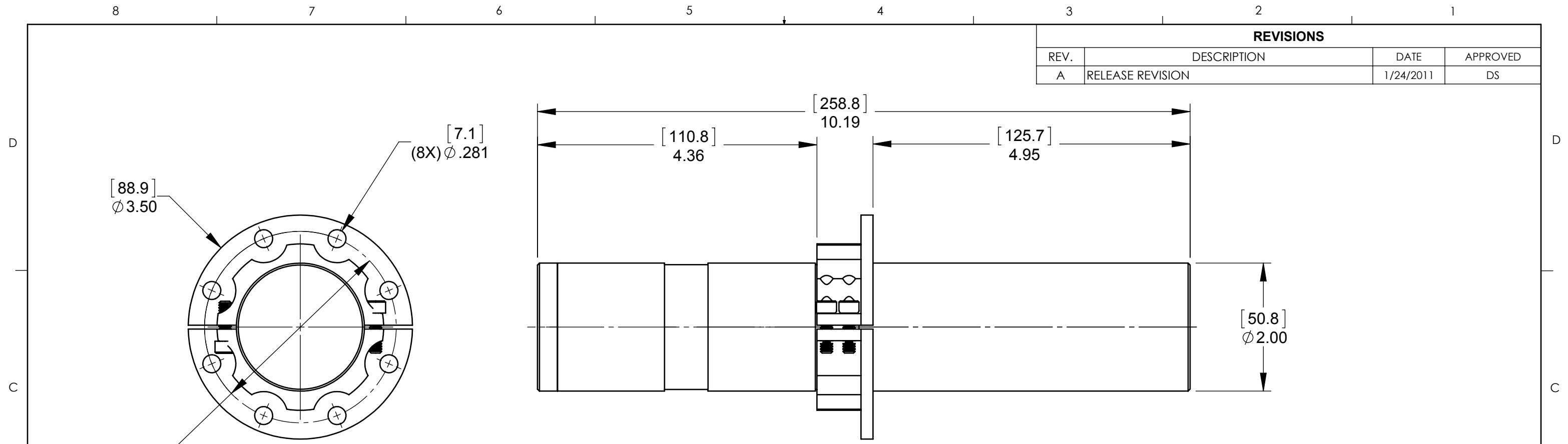

VIEW SHOWING FLANGE IN POSITION 1

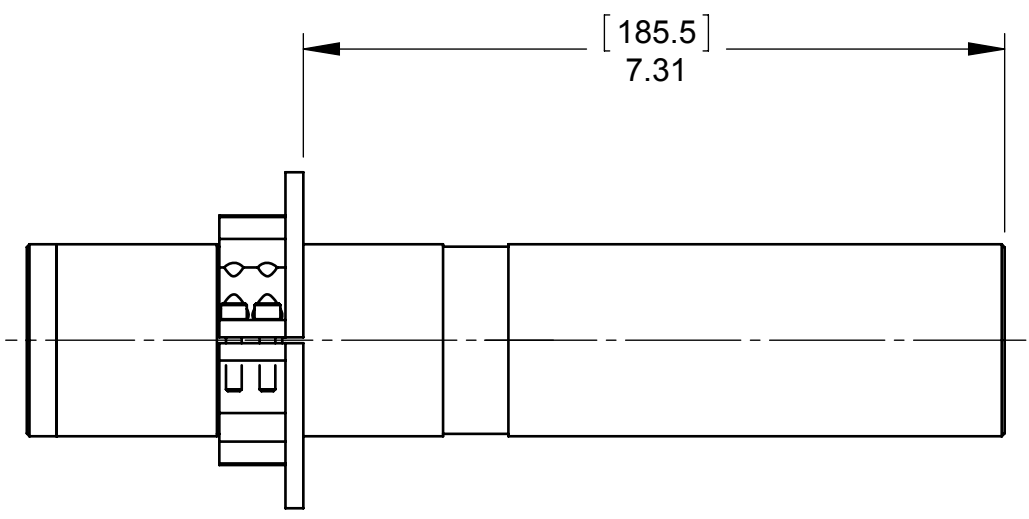

VIEW SHOWING FLANGE IN POSITION 2

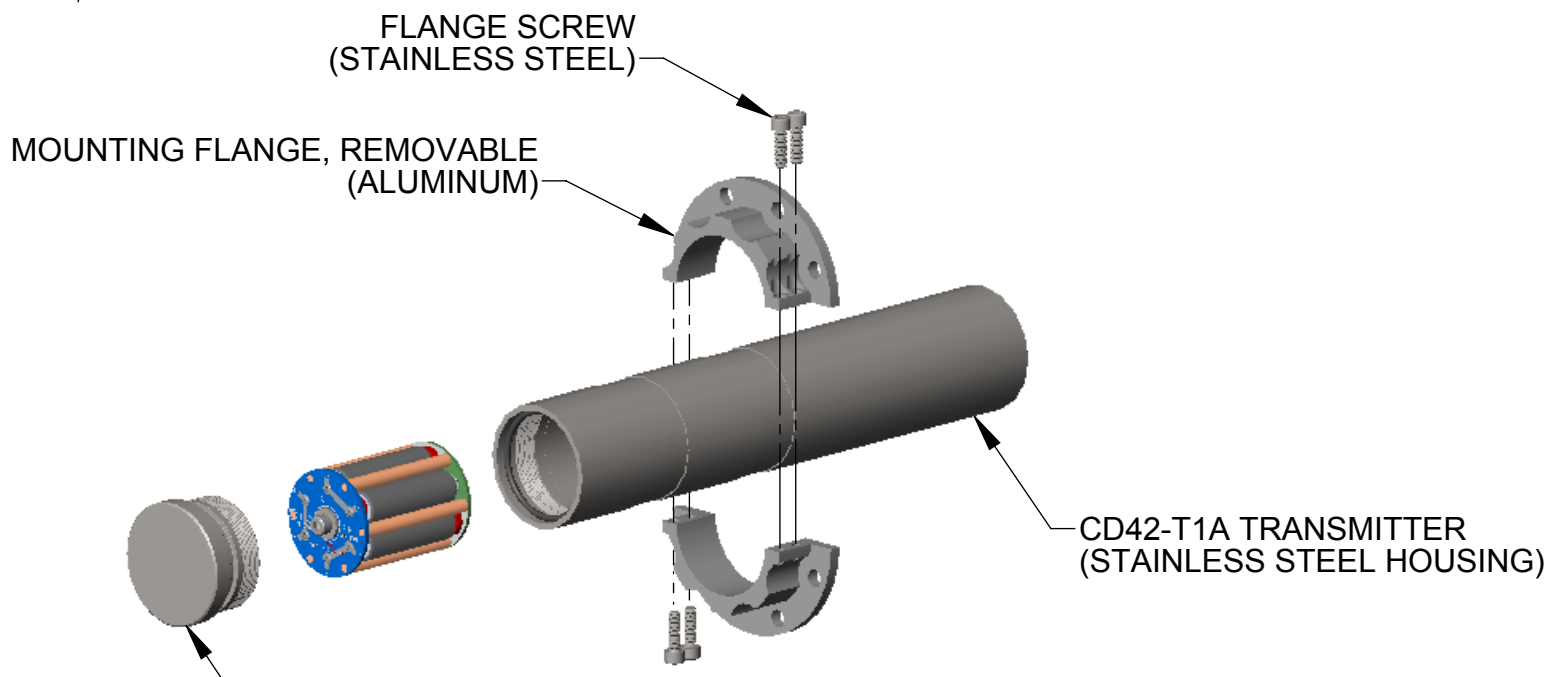

- NOTES:**
1. DIMENSIONS ARE IN INCHES AND [MILLIMETERS].
 2. MAXIMUM OPERATING PRESSURE: 2500 PSI [172 BAR].
 3. APPROXIMATE WEIGHT: 5.5 LB [2.5 KG].
 4. FLANGE HAS 2 POSITIONS OR CAN BE REMOVED.

PROPRIETARY AND CONFIDENTIAL
 THE INFORMATION CONTAINED IN THIS DRAWING IS THE SOLE PROPERTY OF CDI. ANY REPRODUCTION IN PART OR AS A WHOLE WITHOUT THE WRITTEN PERMISSION OF CDI IS PROHIBITED.

		UNLESS OTHERWISE SPECIFIED:	NAME	DATE		
		DIMENSIONS ARE IN INCHES	DRAWN	DS		1/24/2011
		TOLERANCES:	CHECKED			
		FRACTIONAL ± 1/32	ENG APPR.			
		ANGULAR: ± 2°	MFG APPR.			
		TWO PLACE DECIMAL ± .03	Q.A.			
		THREE PLACE DECIMAL ± .010	COMMENTS:			
		INTERPRET GEOMETRIC TOLERANCING PER: ASME Y14.5M - 1994				TITLE:
		MATERIAL				GENERAL ARRANGEMENT, CD42-T1A TRANSMITTER
NEXT ASSY	USED ON	FINISH				SIZE
		DO NOT SCALE DRAWING	ECN #: 01211101			DWG. NO.
						B 81-03-0053-00E
						REV
						A
						SCALE:
						WEIGHT:
						SHEET 1 OF 1